



HIRSCHMANN

A **BELDEN** BRAND

User Manual

Installation Industrial Ethernet Firewall EAGLE One

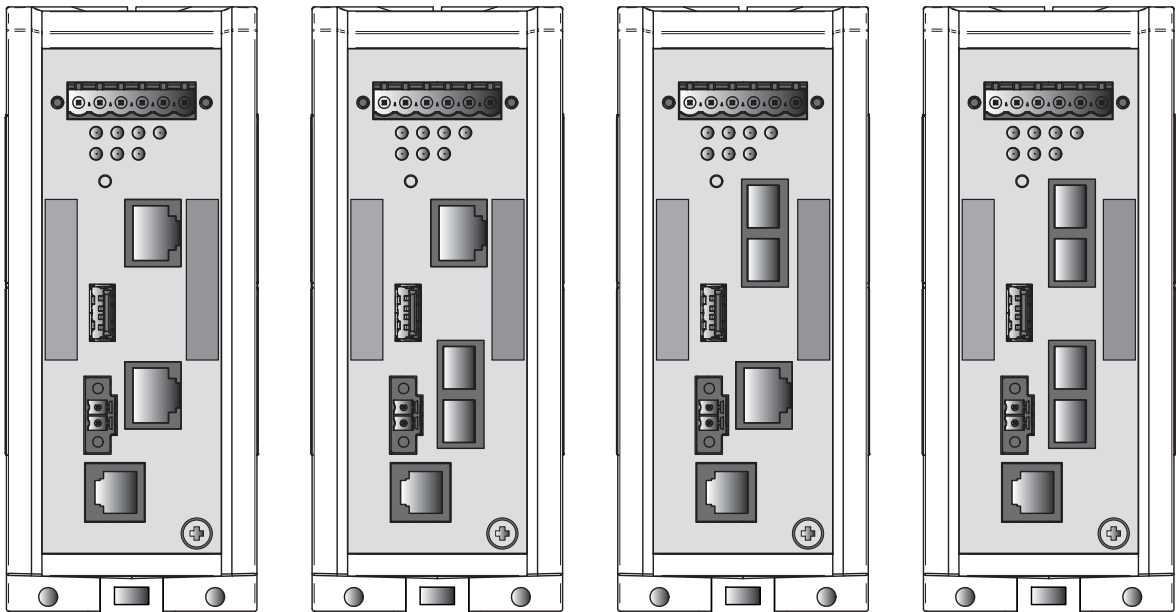

040036001030714000

Installation EAGLE One
Release 03 07/2014

Technical support
<https://hirschmann-support.belden.eu.com>

The naming of copyrighted trademarks in this manual, even when not specially indicated, should not be taken to mean that these names may be considered as free in the sense of the trademark and tradename protection law and hence that they may be freely used by anyone.

© 2014 Hirschmann Automation and Control GmbH

Manuals and software are protected by copyright. All rights reserved. The copying, reproduction, translation, conversion into any electronic medium or machine scannable form is not permitted, either in whole or in part. An exception is the preparation of a backup copy of the software for your own use. For devices with embedded software, the end-user license agreement on the enclosed CD/DVD applies.

The performance features described here are binding only if they have been expressly agreed when the contract was made. This document was produced by Hirschmann Automation and Control GmbH according to the best of the company's knowledge. Hirschmann reserves the right to change the contents of this document without prior notice. Hirschmann can give no guarantee in respect of the correctness or accuracy of the information in this document.

Hirschmann can accept no responsibility for damages, resulting from the use of the network components or the associated operating software. In addition, we refer to the conditions of use specified in the license contract.

You can get the latest version of this manual on the Internet at the Hirschmann product site (www.hirschmann.com).

Printed in Germany
Hirschmann Automation and Control GmbH
Stuttgarter Str. 45-51
72654 Neckartenzlingen
Germany
Tel.: +49 1805 141538

Contents

Safety instructions	5
About this manual	16
Key	16
1 Description	17
1.1 General description	17
1.2 Device name and product code	18
1.3 Combination options	22
1.4 Device view	23
1.5 Power supply	24
1.6 Ethernet ports	24
1.6.1 10/100 Mbit/s twisted pair port	24
1.6.2 100 Mbit/s F/O port	25
1.7 Display elements	25
1.7.1 Device state	25
1.7.2 Additional status information	26
1.7.3 Port state	26
1.8 Management interfaces	26
1.8.1 V.24 interface (external management)	26
1.8.2 ACA21-USB interface	27
1.9 Input/output interfaces	28
1.9.1 Signal contact	28
1.9.2 Digital input	28
2 Installation	29
2.1 Overview	29
2.2 Check the contents of the package	29
2.3 Installing and grounding the device	29
2.3.1 Installing the device onto the DIN rail	30
2.3.2 Mounting on a vertical flat surface	30
2.3.3 Grounding the device	31
2.4 Connecting the terminal blocks	31
2.4.1 Connecting the power supply and signal lines	32
2.4.2 Wiring the digital input (optional)	33
2.5 Operating the device	33
2.6 Connecting data cables	34

3	Configuration	35
3.1	Making basic settings	35
3.2	Firewall and VPN functions	35
3.2.1	Firewall functions	35
3.2.2	VPN functions	36
3.3	Operating modes	36
3.3.1	Delivery state	36
3.3.2	Transparent mode	37
3.3.3	Router mode	37
3.3.4	PPPoE mode	37
3.4	Starting Configuration	37
4	Monitoring the ambient air temperature	39
5	Maintenance and service	40
6	Disassembly	41
7	Technical data	42
A	Further Support	51

Safety instructions

■ General safety instructions

You operate this device with electricity. The proper and safe operation of this device depends on proper handling during transportation, proper storage and assembly, and conscientious operation and maintenance procedures. Improper use of this device is associated with the risk of personal injury or property damage.

- Read this documentation as well as the safety instructions and warnings before connecting any cables.
- Never start operation with damaged components.
- The device does not contain any service components. If the device is not functioning correctly, or if it is damaged, turn off the power supply and return the device to Hirschmann for inspection.

WARNING

UNCONTROLLED MACHINE ACTIONS

To avoid uncontrolled machine actions caused by data loss, configure all the data transmission devices individually.

Before you start any machine which is controlled via data transmission, be sure to complete the configuration of all data transmission devices.

Failure to follow these instructions can result in death, serious injury, or equipment damage.

■ Qualification requirements for personnel

- Only allow qualified personnel to work on the device.

Qualified personnel have the following characteristics:

- ▶ Qualified personnel are properly trained. Training as well as practical knowledge and experience make up their qualifications. This is the prerequisite for grounding and labeling circuits, devices, and systems in accordance with current standards in safety technology.
- ▶ Qualified personnel are aware of the dangers that exist in their work.
- ▶ Qualified personnel are familiar with appropriate measures against these hazards in order to reduce the risk for themselves and others.
- ▶ Qualified personnel receive training on a regular basis.

■ Intended usage

- Use the product only for the application cases described in the Hirschmann product information, including this manual.
- Operate the product only according to the technical specifications.

See [“Technical data” on page 42.](#)

- Connect to the product only components suitable for the requirements of the specific application case.

■ **National and international safety regulations**

- Verify that the electrical installation meets local or nationally applicable safety regulations.

■ **Grounding the device**

Grounding the device is by means of a separate ground connection on the device.

- Ground the device before connecting any other cables.
- Disconnect the grounding only after disconnecting all other cables.

The overall shield of a connected shielded twisted pair cable is connected to the ground connector on the front panel as a conductor.

■ **Working voltage**

The working voltage is electrically isolated from the housing.

- Connect only a working voltage that corresponds to the type plate of your device.
- Every** time you connect the electrical conductors, make sure that the following requirements are met:
 - ▶ The power supply conforms to overvoltage category I or II.
 - ▶ The power supply has an easily accessible disconnecting device (e.g., a switch or a plug). This disconnecting device is clearly identified. So in the case of an emergency, it is clear which disconnecting device belongs to which power supply cable.
 - ▶ The electrical wires are voltage-free.
 - ▶ The power supply is Class 2 compliant.
 - ▶ The working voltage inputs are designed for operation with safety extra-low voltage. Connect only SELV circuits with voltage restrictions in line with IEC/EN 60950-1 to the working voltage connections.
 - ▶ Supply with AC voltage:
A fuse is located in the outer conductor of the power supply. The neutral conductor is on ground potential. Otherwise, a fuse is also located in the neutral conductor.
Regarding the properties of this fuse: See [“General technical data” on page 42.](#)

- ▶ Supply with DC voltage:
A fuse suitable for DC voltage is located in the plus conductor of the power supply.
The minus conductor is on ground potential. Otherwise, a fuse is also located in the minus conductor.
Regarding the properties of this fuse: [See “General technical data” on page 42.](#)
- ▶ The wire diameter of the power supply cable is at least 1 mm² (North America: AWG16) on the working voltage input.
- ▶ The cross-section of the protective conductor is the same size as or bigger than the cross-section of the power supply cables.
- ▶ The power supply cables used are permitted for the temperature range required by the application case.
- ▶ Relevant for North America:
Use 60/75 or 75 °C copper (Cu) wire only.
- Internal fuses are triggered solely in the case of a detected error in the device. In case of damage or malfunction of the device, turn off the working voltage and return the device to the plant for inspection.

■ **Input/output interfaces**

Every time you connect the electrical conductors, make sure that the following requirements are met:

- ▶ The electrical wires are voltage-free.
- ▶ The connected voltage is limited by a current limitation device or a fuse.

Observe the electrical threshold values for the signal contact.

[See “General technical data” on page 42.](#)

Observe the electrical threshold values for the digital input.

[See “Digital input” on page 44.](#)

■ **Installation site requirements**

- Verify that there is at least 4 in (10 cm) of space above and below the device.
- Verify that there is at least 0.8 in (2 cm) of space on the right and left sides of the device.
- Install the device in a fire protected enclosure according to EN 60950-1.

■ **Housing**

Only technicians authorized by the manufacturer are permitted to open the housing.

- Never insert pointed objects (narrow screwdrivers, wires, etc.) into the device or into the connection terminals for electric conductors. Do not touch the connection terminals.
- Keep the ventilation slits free to ensure good air circulation.
- Install the device in the vertical position.
- At ambient temperatures > 140 °F (60 °C):
The surfaces of the device housing may become hot. Avoid touching the device while it is operating.

■ **LED or laser components**

LED or LASER components according to IEC 60825-1 (2007):
CLASS 1 LASER PRODUCT
CLASS 1 LED PRODUCT

■ **CE marking**

The labeled devices comply with the regulations contained in the following European directive(s):

2004/108/EC (EMC)

Directive of the European Parliament and the council for standardizing the regulations of member states with regard to electromagnetic compatibility.

2011/65/EU (RoHS)

Directive of the European Parliament and of the Council on the restriction of the use of certain hazardous substances in electrical and electronic equipment.

In accordance with the above-named EU directive(s), the EU conformity declaration will be at the disposal of the relevant authorities at the following address:

Hirschmann Automation and Control GmbH
Stuttgarter Str. 45-51
72654 Neckartenzlingen
Germany
Tel.: +49 1805 141538

The device can be used in the industrial sector.

- ▶ Interference immunity: EN 61000-6-2
- ▶ Emitted interference: EN 55022

You find more information on technical and industry standards here:

[“Technical data” on page 42](#)

Warning! This is a class A device. This device can cause interference in living areas, and in this case the operator may be required to take appropriate measures.

Note: The assembly guidelines provided in these instructions must be strictly adhered to in order to observe the EMC threshold values.

■ **Relevant for use in North America**

Use this device solely in Class 2 Circuits.

■ **Relevant for USE in Hazardous Locations Class I Division 2, Groups A, B, C, D**

The **relay connections and the USB connections** are to be installed and used within their Entity Parameters as per Control Drawing 000174247DNR – details see the next two pages.

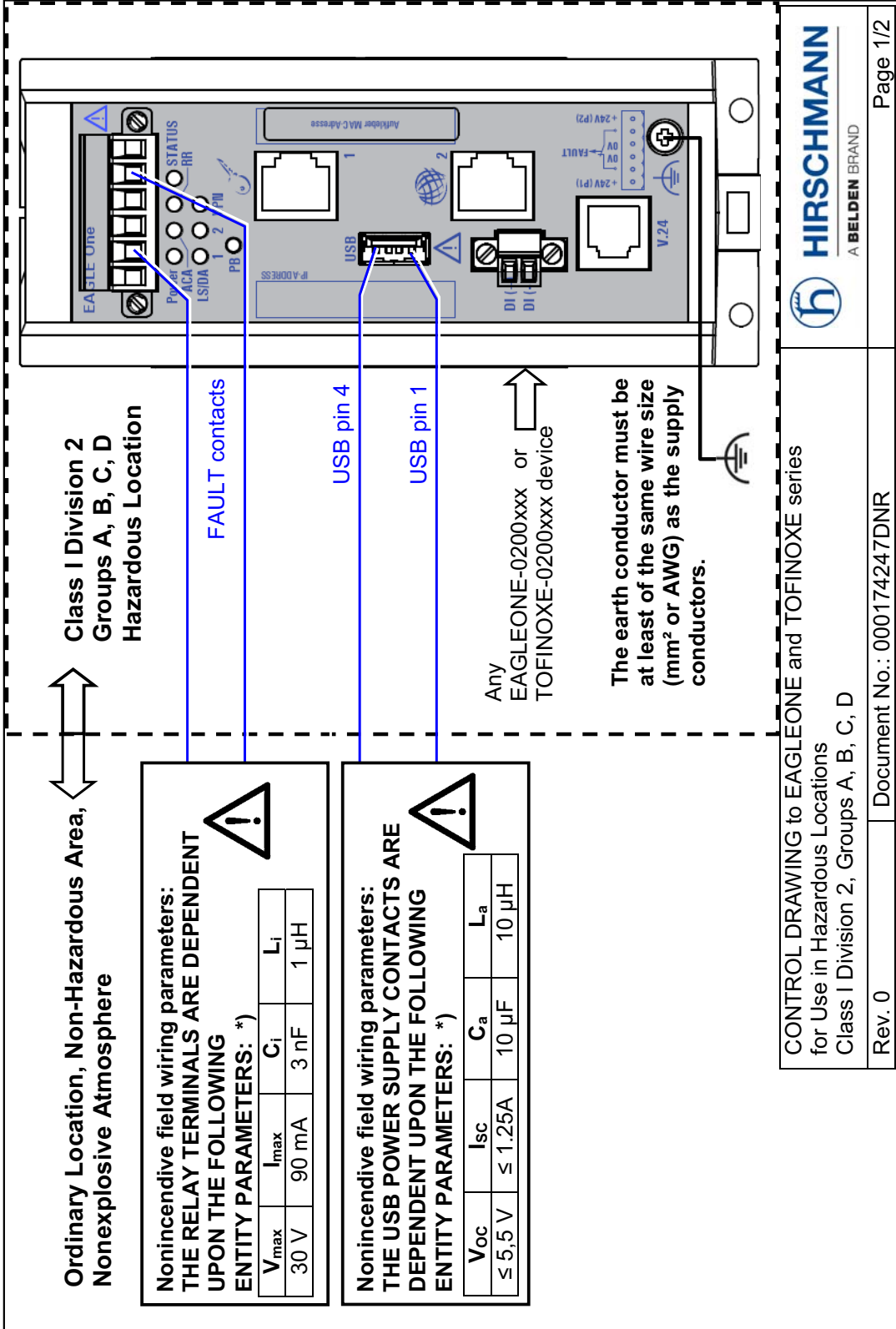

SUITABLE FOR USE IN CLASS I DIVISION 2 GROUPS A, B, C, D HAZARDOUS LOCATIONS, OR NONHAZARDOUS LOCATIONS ONLY. For use in **HARDOUS LOCATIONS** only allowed for model No.'s. which are labelled accordingly.

Nonincendive field wiring circuits must be wired in accordance with the National Electrical Code (NEC), NFPA 70 , article 501.
USB AND RELAY CONTACTS (FAULT): Install per Control Drawing 000174247DNR.



WARNING - EXPLOSION HAZARD – SUBSTITUTION OF ANY COMPONENTS MAY IMPAIR SUITABILITY FOR CLASS I DIVISION 2.

WARNING - EXPLOSION HAZARD - DO NOT DISCONNECT EQUIPMENT WHILE THE CIRCUIT IS LIVE OR UNLESS THE AREA IS KNOWN TO BE FREE OF IGNITABLE CONCENTRATIONS..

***) Notes:**

The nonincendive field wiring circuit concept allows interconnection of nonincendive field wiring apparatus and associated nonincendive field wiring apparatus using any of the wiring methods permitted for unclassified locations when certain parametric conditions are met.

Capacity: $C_a \geq C_i + C_{\text{Cable}}$; **Inductivity:** $L_a \geq L_i + L_{\text{Cable}}$

The maximum cable length has to be determined as follows:

(a) max. Cable Length $< (L_a - L_i) / \text{Cable } L$

"Cable L " denotes the inductance per unit length of used cable) **and**

(b) max. Cable Length $< (C_a - C_i) / \text{Cable } c$

("Cable c " denotes the capacitance per unit length of used cable).

The lower value of (a) and (b) is to apply.

Manufactured in 72654 Neckartenzlingen / Germany by Hirschmann Automation and Control GmbH.
 DOM: ww/yyyy (Date of manufacturer w - week, Y - year. Refer to the device label).

 HIRSCHMANN A BELDEN BRAND	
CONTROL DRAWING to EAGLEONE and TOFINOXE series for Use in Hazardous Locations Class I Division 2, Groups A, B, C, D	Document No.: 000174247DNR
Rev. 0	Page 2/2

■ **Relevant for use in Ex Zone 2 according to ATEX 95 (European directive 94/9/EC)**

In Ex Zone 2, only the devices with a corresponding label may be operated.

The **USB contacts** are to be installed and used within their Entity Parameters as per Control Drawing 000174247DNR according to the European directive 94/9/EC – details see the next two pages.

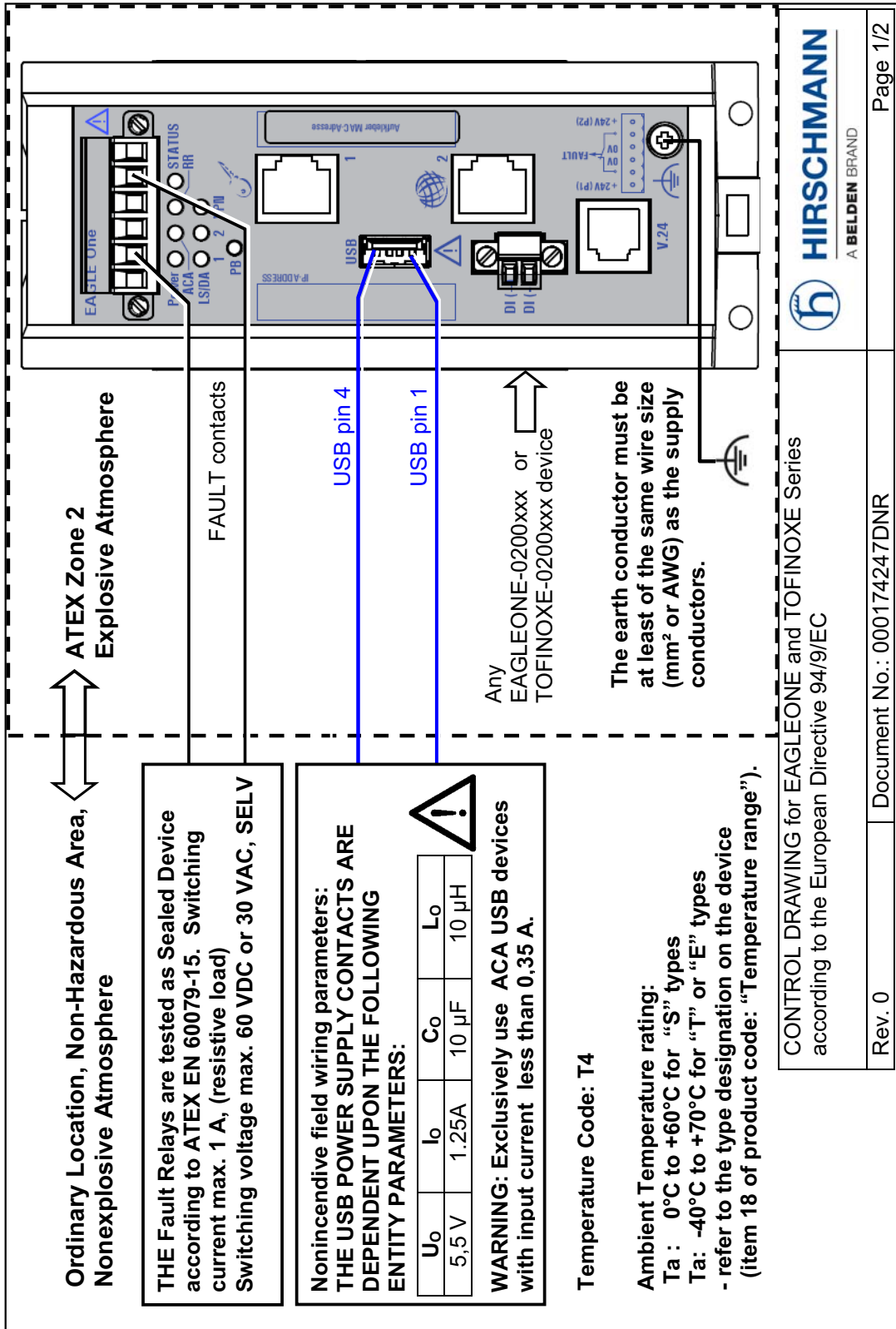

For Use in explosive atmospheres according to the European directive 94/9/EC:

Applied Standards: EN60079-0, 2012
EN60079-11, 2012
EN60079-15, 2010



The Use in Hazardous Locations with explosive atmospheres is only allowed for EAGLEONE or TOFINOXE model No's. which are labeled accordingly – including “8 II 3G” , “Ex nA IIC ic T4 Gc” , “DEKRA 13ATEX0184X”

SPECIAL CONDITIONS FOR SAFE USE:

- The modules shall be installed in a suitable enclosure providing a degree of protection of at least IP54 according to EN60529, taking into account the environmental conditions under which the equipment will be used.
- Provisions shall be made to prevent the rated voltage from being exceeded by transient disturbances of more than 119V.
- When the temperature under rated conditions exceeds 70°C at the cable or conduit entry point, or 80°C at the branching point of the conductors, the temperature specification of the selected cable shall be in compliance with the actual measured temperature values.

Manufactured in 72654 Neckartenzlingen / Germany by Hirschmann Automation and Control GmbH.
DOM: ww/yyyy (Date of manufacture w - week, Y - year. Refer to the device label).

CONTROL DRAWING to EAGLEONE and TOFINOXE series
according to the European Directive 94/9/EC



HIRSCHMANN
A BELDEN BRAND

Rev. 0

Document No.: 000174247DNR

Page 2/2

■ **FCC note:**

This device complies with part 15 of the FCC rules. Operation is subject to the following two conditions: (1) this device may not cause harmful interference; (2) this device must accept any interference received, including interference that may cause undesired operation.

Appropriate testing has established that this device fulfills the requirements of a class A digital device in line with part 15 of the FCC regulations.

These requirements are designed to provide sufficient protection against interference when the device is being used in a business environment.

The device creates and uses high frequencies and can also radiate these frequencies. If it is not installed and used in accordance with this operating manual, it can cause radio transmission interference. The use of this device in a residential area can also cause interference, and in this case the user is obliged to cover the costs of removing the interference.

■ **Recycling note**

After usage, this device must be disposed of properly as electronic waste, in accordance with the current disposal regulations of your county, state, and country.

About this manual

The “Installation” user manual contains a device description, safety instructions, a description of the display, and the other information that you need to install the device.

The following manuals are available as PDF files on the CD/DVD supplied:

- ▶ Installation user manual
- ▶ Configuration user manual
- ▶ Command Line Interface user manual
- ▶ Reference manual for the graphical user interface

The Industrial HiVision network management software provides you with additional options for smooth configuration and monitoring:

- ▶ ActiveX control for SCADA integration
- ▶ Auto-topology discovery
- ▶ Browser interface
- ▶ Client/server structure
- ▶ Event handling
- ▶ Event log
- ▶ Simultaneous configuration of multiple devices
- ▶ Graphical user interface with network layout
- ▶ SNMP/OPC gateway

Key

The symbols used in this manual have the following meanings:

▶	Listing
□	Work step
■	Subheading

1 Description

1.1 General description

The EAGLE One devices support the authentication, security and confidentiality of communication within production networks, but also beyond company boundaries.

The EAGLE One devices support the following network modes:

- ▶ Transparent mode
- ▶ Router mode
- ▶ PPPoE mode

The EAGLE One devices are used everywhere that security-sensitive network cells require a connection from the internal network to the external network. The EAGLE One devices are the link between the internal network and the external network from which unauthorized access is possible. In its function as a link, the EAGLE One devices help you to protect the security-sensitive cell from undesired data traffic along the connection to the external network.

Typical uses are:

- ▶ Helping protect individual production cells in a flat company network
- ▶ Helping protect individual production cells in a routed company network
- ▶ Coupling identical production cells to a company network
- ▶ Connecting a production cell with the office network via a public network
- ▶ Helping provide protected service access
- ▶ Separation of machine common parts

You can choose from between a wide range of variants. You have the option to set up your device individually based on different criteria:

- ▶ Types of connectors
- ▶ Temperature range
- ▶ Certifications

The EAGLE One devices are designed for the special requirements of industrial automation. They meet the relevant industry standards, provide very high operational reliability, even under extreme conditions, and also long-term reliability and flexibility.

The devices allow you to set up switched and routed industrial Ethernet networks that conform to the IEEE 802.3 standard.

The following installation options are available:

- ▶ simply snapping them onto a DIN rail
- ▶ Mounting on a vertical flat surface

The devices work without a fan.

There are convenient options for managing the device. Administer your devices via:

- ▶ Network management software (e.g. Industrial HiVision)
- ▶ a Web browser
- ▶ a V.24 interface (locally on the device)
- ▶ HiDiscovery (Software for putting the device into operation)
- ▶ SSH

The devices provide you with a large range of functions, which the manuals for the operating software inform you about. You will find these manuals as PDF files on the enclosed CD/DVD, or you can download them from the Internet on the Hirschmann product pages (www.hirschmann.com).

1.2 Device name and product code

The device name corresponds to the product code. The product code is made up of characteristics with defined positions. The characteristic values stand for specific product properties.

Item	Product characteristic	Characteristic value	Description
1 ... 8	Device	EAGLEONE	2 port Eagle router
9	–		
10 ... 11	Number: Fast Ethernet ports	02	2 × Fast Ethernet ports
12 ... 13	Number: Gigabit Ethernet ports	00	0 × Gigabit Ethernet ports
14 ... 15	Ethernet port 1 INTERNAL	T1	1 × RJ45 socket for 10/100 Mbit/s twisted pair connections
		M2	1 × DSC multimode socket for 100 Mbit/s F/O port
16 ... 17	Ethernet port 2 EXTERNAL	T1	1 × RJ45 socket for 10/100 Mbit/s twisted pair connections
		M2	1 × DSC multimode socket for 100 Mbit/s F/O port

Table 1: Device name and product code

Item	Product characteristic	Characteristic value	Description
18	Temperature range	E	Extended with conformal coating -40 °F ... +158 °F (-40 °C ... +70 °C)
		S	Standard +32 °F ... +140 °F (0 °C ... +60 °C)
		T	Extended -40 °F ... +158 °F (-40 °C ... +70 °C)
19 ... 20	Working voltage	DD	2 voltage inputs for redundant power supply Rated voltage range DC 12 V ... 48 V Nominal voltage AC 24 V
21 ... 22	Certificates and declarations	Note: You will find detailed information on the certificates and declarations applying to your device in a separate overview. See table 3 on page 21.	
23 ... 26	Software packages	0000	Basic Software-Packages
27 ... 28	Customer-specific version	HH	Hirschmann standard
29	Software configuration	E	Entry (Hirschmann standard configuration)
30 ... 34	Software version	05.3	Software version 05.3
		XX.X	Current software version
35 ... 36	Bug fix	00	Bugfix version 00
		XX	Current bugfix version

Table 1: Device name and product code

	Item	Product characteristic	Description
EAGLEONE	1 ... 8	Device	2 port Eagle router
-	9	-	
02	10 ... 11	Number: Fast Ethernet ports	2 × Fast Ethernet ports
00	12 ... 13	Number: Gigabit Ethernet ports	0 × Gigabit Ethernet ports
T1	14 ... 15	Ethernet port 1 INTERNAL	1 × RJ45 socket for 10/100 Mbit/s twisted pair connections
T1	16 ... 17	Ethernet port 2 EXTERNAL	1 × RJ45 socket for 10/100 Mbit/s twisted pair connections
E	18	Temperature range	Extended with conformal coating -40 °F ... +158 °F (-40 °C ... +70 °C)
DD	19 ... 20	Working voltage	2 voltage inputs for redundant power supply Rated voltage range DC 12 V ... 48 V Nominal voltage AC 24 V
Z9	21 ... 22	Certificates and declarations	Standard applications ▶ CE ▶ EN 60950-1 ▶ EN 61131-2 ▶ FCC
0000	23 ... 26	Software packages	Basic Software-Packages
HH	27 ... 28	Customer-specific version	Hirschmann standard
E	29	Software configuration	Entry (Hirschmann standard configuration)
XX.X	30 ... 34	Software version	Current software version
XX	35 ... 36	Bug fix	Current bugfix version

Table 2: Sample product code (left column):

Application case	Certificates and declarations	Characteristic value														
		T9	TY	U9	UT	UX	UY	V9	VT	VU	VY	W9	WX	X9	Y9	Z9
Standard applications	CE	X	X	X	X	X	X	X	X	X	X	X	X	X	X	X
	EN 60950-1	X	X	X	X	X	X	X	X	X	X	X	X	X	X	X
	EN 61131-2	X	X	X	X	X	X	X	X	X	X	X	X	X	X	X
	FCC	X	X	X	X	X	X	X	X	X	X	X	X	X	X	X
	UL 508		X		X	X	X		X	X	X		X	X	X	
Oil and gas applications	ATEX Zone 2											X	X			
	ISA 12.12.01 – Class I, Div. 2					X							X	X		
Substation applications	IEC 61850-3							X	X	X	X					
	IEEE 1613							X	X	X	X					
Navy applications	GL			X	X	X	X			X						
Railway applications (trackside)	EN 50121-4	X	X		X				X							

Table 3: Assignment: application cases, certificates and declarations, characteristic values

1.3 Combination options

Item	1 ... 8	9	10 ... 11	12 ... 13	14 ... 15	16 ... 17	18	19 ... 20	21 ... 22	23 ... 26	27 ... 28	29	30 ... 34	35 ... 36
Product characteristic	Device	Number: Fast Ethernet ports	Number: Gigabit Ethernet ports	Ethernet port 1	Ethernet port 2	Temperature range	Working voltage	Certificates and declarations	Software packages	Custom-specific version	Software configuration	Software version	Bug fix	
Attribute values	EAGL EONE	- 02	00	T1; M2	T1; M2	E; S; T	DD	T9; TY; U9; UY; UX; UT; V9; VY; VU; VT; W9; WX; X9; Y9; Z9	0000	HH	E	05.3; XX.X	00; XX	

Table 4: Combination options of the EAGLE One device variants

1.4 Device view

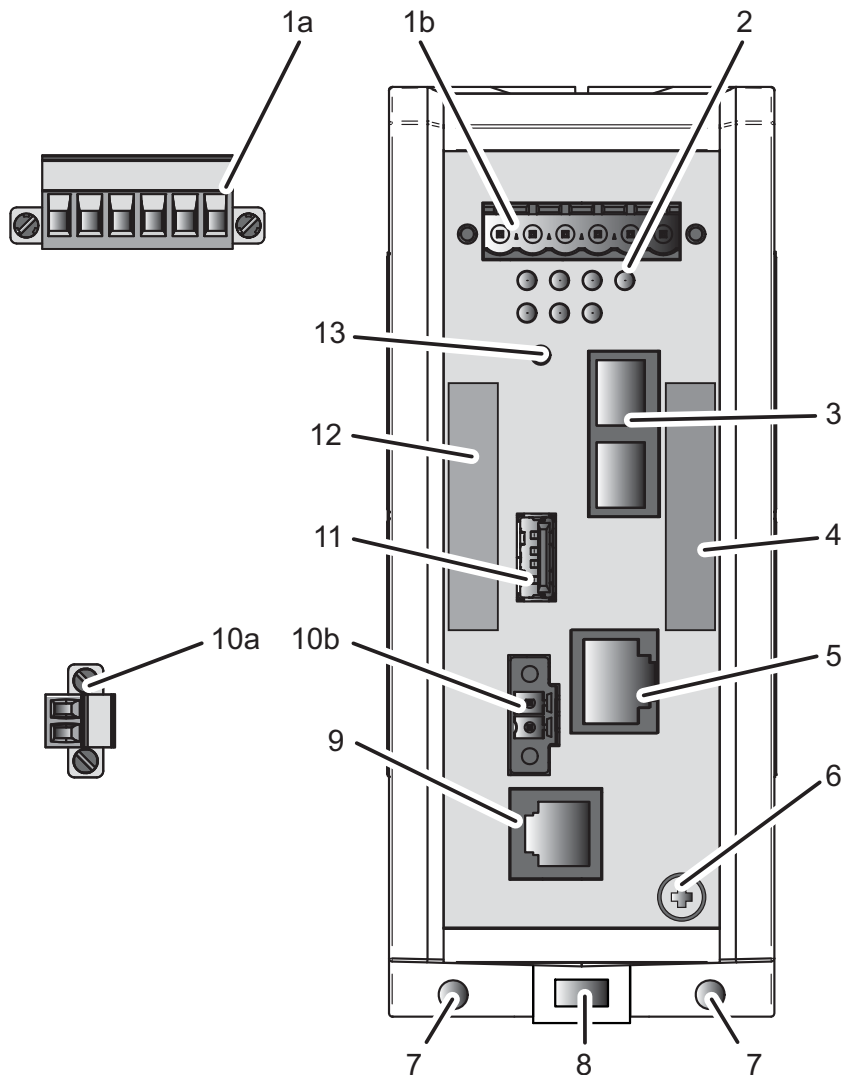

1a	6 pin, screwable terminal block for redundant supply voltage and signal contact
1b	Terminal block connection
2	LED display elements
3	Ethernet port 1 INTERNAL
	alternatively, depending on device variant
	RJ45 socket for 10/100 Mbit/s twisted pair connections DSC multimode socket for 100 Mbit/s F/O port
4	MAC address of device (label)
5	Ethernet port 2 EXTERNAL
	alternatively, depending on device variant
	RJ45 socket for 10/100 Mbit/s twisted pair connections DSC multimode socket for 100 Mbit/s F/O port
6	Grounding screw
7	Hole for mounting using a wall mounting plate
8	Locking gate for removing the device
9	V.24 interface
10a	2 pin, screwable terminal block for digital input

Table 5: Front view (using the example Eagle-One-0200M2T1.....)

10b	Terminal block connection
11	ACA21-USB interface
12	Label area for IP address of device
13	Button (no function in the existing device version)

Table 5: Front view (using the example Eagle-One-0200M2T1.....)

1.5 Power supply

A 6-pin, screwable terminal block is available for the redundant supply to the device.

For further information see [“Working voltage” on page 6](#).

1.6 Ethernet ports

1.6.1 10/100 Mbit/s twisted pair port

The 10/100 Mbit/s twisted pair port offers you the ability to connect network components according to the IEEE 802.3 10BASE-T/100BASE-TX standard.

This port supports:

- ▶ Autocrossing (if autonegotiation is activated)
- ▶ Autonegotiation
- ▶ Autopolarity
- ▶ 10 Mbit/s half-duplex mode, 10 Mbit/s full duplex mode
- ▶ 100 Mbit/s half-duplex mode, 100 Mbit/s full duplex mode

Delivery state: autonegotiation active

The socket housing is electrically connected with the front panel.

The pin assignment corresponds to MDI-X.

	Pin	Function
	1	RD+ Receive path
	2	RD- Receive path
	3	TD+ Transmission path
	6	TD- Transmission path
	4,5,7,8	—

Table 6: Pin assignment of the 10/100 Mbit/ twisted pair port, RJ-45 socket, MDI-X mode

1.6.2 100 Mbit/s F/O port

The 100 Mbit/s F/O port offers you the ability to connect network components according to the IEEE 802.3 100BASE-FX standard.

This port supports:

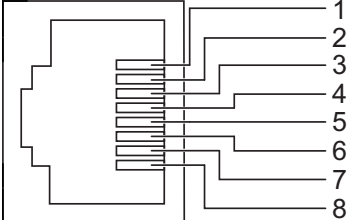
- ▶ Full or half duplex mode

Default setting: Full duplex

1.7 Display elements

After the operating voltage is set up, the software starts and initializes itself. Afterwards, the device performs a self-test.

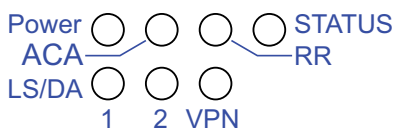

1.7.1 Device state

These LEDs provide information about conditions which affect the operation of the whole device.

LED	Display	Color	Activity	Meaning
Power	Working voltage	—	None	Working voltage is too low
		Yellow	Lights up	Working voltage 1 or 2 is on
		Green	Lights up	Working voltages 1 and 2 are on
Status	Device Status	—	None	Device is starting and/or is not ready for operation
		Green	Lights up	Device is ready for operation. Characteristics can be configured
		Red	Lights up	The signal contact is open - it is reporting a detected error.
RR	Router redundancy	—	None	No router redundancy configured.
		Green	Lights up	The device is in the Router Redundancy Master mode.
		Yellow	Long flashing Lights up	The device is in the Router Redundancy Backup mode. The device is in the Router Redundancy Master mode, and the communication with the backup device is disturbed.
ACA	Storage medium ACA21-USB	—	None	No ACA connected
		Green	Lights up	ACA storage medium connected
			Flashes 1 time a period	The device writes to the storage medium.
			Flashing 2 times a period	The device reads from the storage medium.
	Yellow	Lights up	ACA storage medium inoperative	

1.7.2 Additional status information

LED	Display	Color	Activity	Meaning
VPN	Virtual Private Network	—	None	At least one of the following cases applies: <ul style="list-style-type: none">▶ The VPN status display is switched off.▶ No VPN connection is active.▶ No active VPN connection is in the "up" status.
		Green	Lights up	The VPN status display is switched on, and at least 1 VPN connection is active and in the "up" status.

1.7.3 Port state

These LEDs display port-related information.

LED	Display	Color	Activity	Meaning
LS/DA	Link status	—	None	Device detects an invalid or missing link
		Green	Lights up	Device detects a valid link
			Flashes 3 times a period	Port is switched off
		Yellow	Flashing	Device is transmitting and/or receiving data

1.8 Management interfaces

1.8.1 V.24 interface (external management)

The V.24 interface is a serial interface for the local connection of an external management station (VT100 terminal or PC with terminal emulation). The interface allows you to set up a data connection to the Command Line Interface (CLI) and to the system monitor.

The V.24 interface is an RJ11 socket.

VT 100 terminal settings

Speed	9,600 Baud
Data	8 bit
Stopbit	1 bit
Handshake	off
Parity	none

The socket housing is electrically connected to the front panel of the device. The V.24 interface is electrically insulated from the working voltage.

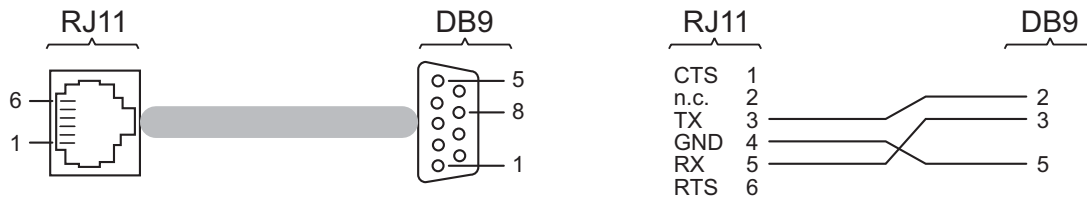

Figure 1: Pin assignment of the V.24 interface and the DB9 connector

Note: You find the order number for the terminal cable, which is available as accessory, under [“Accessories”](#) on page 48.

1.8.2 ACA21-USB interface

This interface offers you the ability to connect the storage medium AutoConfiguration AdapterACA21-USB. This storage medium is used for saving/loading the configuration and diagnostic functions, and for loading the software.

The USB interface has the following properties:

- ▶ Supports the USB master mode
- ▶ Supports USB 1.1 (data rate max. 12 MBit/s)
- ▶ Connectors: type A
- ▶ Supplies current of max. 500 mA
- ▶ Voltage not potential-separated

Figure	Pin	Operation
	1	VCC (VBus)
	2	- Data
	3	+ Data
	4	Ground (GND)

Table 7: Pin assignment of the USB interface

1.9 Input/output interfaces

1.9.1 Signal contact

The signal contact is a potential-free relay contact.

The device allows you to perform remote diagnosis via the signal contact. In the process, the device signals events such as a line interruption. When an event occurs, the device opens the relay contact and interrupts the closed circuit. The management setting specifies which events switch a contact. You can also use the management to switch the signal contact manually and thus control external devices.

For further information see [“Working voltage” on page 6](#).

1.9.2 Digital input

For further information see [“Working voltage” on page 6](#).

2 Installation

Before installing and starting up the device, read the safety instructions. See [“Safety instructions” on page 5](#).

2.1 Overview

The devices have been developed for practical application in a harsh industrial environment.

On delivery, the device is ready for operation.

The following steps should be performed to install and configure a device:

- ▶ [Check the contents of the package](#)
- ▶ [Installing and grounding the device](#)
- ▶ [Connecting the power supply and signal lines](#)
- ▶ [Wiring the digital input \(optional\)](#)
- ▶ [Operating the device](#)
- ▶ [Connecting data cables](#)

2.2 Check the contents of the package

- Check whether the package includes all items named in the section [“Scope of delivery” on page 48](#).
- Check the individual parts for transport damage.

2.3 Installing and grounding the device



WARNING

FIRE HAZARD

Install the device in a fire protected enclosure according to EN 60950-1.

Failure to follow these instructions can result in death, serious injury, or equipment damage.

2.3.1 Installing the device onto the DIN rail

- Verify that there is at least 4 in (10 cm) of space above and below the device.
- Verify that there is at least 0.8 in (2 cm) of space on the right and left sides of the device.

To mount the device onto a horizontally mounted 35 mm DIN rail according to DIN EN 60715, proceed as follows:

- Slide the upper snap-in guide of the device into the DIN rail.
- Pull down the locking gate using a screwdriver and press the lower part of the device against the DIN rail.
- Snap in the device by releasing the locking gate.

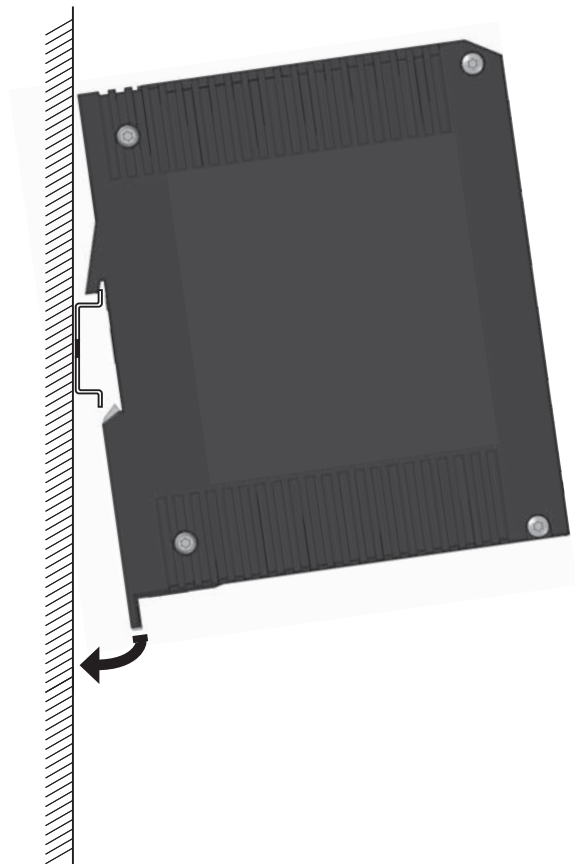

2.3.2 Mounting on a vertical flat surface

You have the option of attaching the device to a vertical flat surface. This requires a wall mounting plate, which you purchase as a separate accessory. See [“Accessories” on page 48](#).

The wall mounting plate comes without mounting hardware.

- Obtain mounting hardware which is suitable for your requirements.

The wall mounting plate includes instructions that take you through the mounting procedure.

- Follow the mounting instructions enclosed with the accessory.

2.3.3 Grounding the device

WARNING

ELECTRIC SHOCK

Ground the device before connecting any other cables.

Failure to follow these instructions can result in death, serious injury, or equipment damage.

The device has a functional ground connection.

The device is grounded via the separate ground screw.

Ground the device via the ground screw.

2.4 Connecting the terminal blocks

WARNING

ELECTRIC SHOCK

Never insert pointed objects (narrow screwdrivers, wires, etc.) into the device or into the connection terminals for electric conductors. Do not touch the connection terminals.

Start connecting the electrical wires only if **all** the above safety requirements are fulfilled.

[See “Working voltage” on page 6.](#)

[See “Input/output interfaces” on page 7.](#)

Failure to follow these instructions can result in death, serious injury, or equipment damage.

2.4.1 Connecting the power supply and signal lines

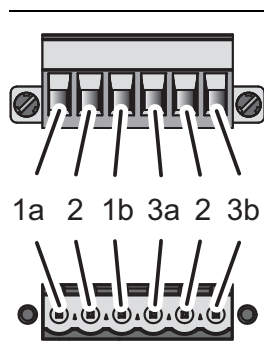

1	Power supply connection 1
1a	24 V
1b	0 V
2	Connection for the signal contact
3	Power supply connection 2
3a	0 V
3b	24 V

Table 8: Pin assignment: 6 pin, screwable terminal block (on the top), connection to the device (at the bottom)

■ Working voltage

The working voltage can be connected redundantly. Both inputs are uncoupled. There is no distributed load. With redundant supply, the power supply unit with the higher output voltage supplies the device on its own. The working voltage is electrically isolated from the housing. With non-redundant supply of the operating voltage, the device reports the loss of an operating voltage. You can prevent this message by applying the operating voltage via both inputs, or by changing the configuration in the Management.

Type of the voltages that can be connected	Specification of the working voltage	Pin assignment on the device
DC voltage	Rated voltage range DC 12 V ... 48 V	24 V Plus terminal of the working voltage
	Voltage range DC incl. maximum tolerances 9.6 V ... 60 V	0 V Minus terminal of the working voltage
AC voltage	Nominal voltage AC 24 V	24 V Outer conductor
	Voltage range AC incl. maximum tolerances 18 V ... 30 V	0 V Neutral conductor

Table 9: Type and specification of the working voltage, pin assignment on the device

- Remove the power connector from the device.
- Connect the wires according to the pin assignment on the device with the clamps.
- Fasten the wires connected by tightening the terminal screws.

■ Signal contact (optional)

- Connect the wires according to the pin assignment on the device with the clamps.
- Fasten the wires connected by tightening the terminal screws.

2.4.2 Wiring the digital input (optional)

	Pin	Signal, terminal	Function
	1	DI (+)	Signal input
	2	DI (-)	Reference potential

Table 10: Pin assignment: 2 pin, screwable terminal block (on the left), connection to the device (to the right)

- Remove the power connector from the device.
- Connect the wires according to the pin assignment on the device with the clamps.
- Fasten the wires connected by tightening the terminal screws.

2.5 Operating the device

WARNING

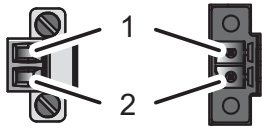
ELECTRIC SHOCK

Connect only a working voltage that corresponds to the type plate of your device.

Failure to follow these instructions can result in death, serious injury, or equipment damage.

Note: The torque for tightening the working voltage terminal block on the device is 4.5 lb-in (0.51 Nm).
The torque for tightening the terminal block on the digital input of the device is 3 lb-in (0.34 Nm).

- Mount the terminal block for the operating voltage and the signal contact using screws.
- Optional: Mount the terminal block for the digital input by screwing.
- Enable the working voltage.

2.6 Connecting data cables

In general, adhere to the following recommendations for data cable connections in environments with high electrical interference levels:

- ▶ Keep the length of the data cables as short as possible.
- ▶ Use optical data cables for the data transmission between the buildings.
- ▶ When using copper cables, provide a sufficient gap between the power supply cables and the data cables. Ideally, install the cables in separate cable channels.
- ▶ Use shielded cables.

Note: Verify that you connect only optical ports with the same optical transmission properties with each other.

For further information see [“10/100 Mbit/s twisted pair port” on page 24](#).

For further information see [“100 Mbit/s F/O port” on page 25](#).

- Connect the device via the INTERNAL port to the internal network or the local computer that you want to help protect.
- Connect the device via the EXTERNAL port to the external network, such as the Internet. This network is used to set up the connections to the external device or external network.

3 Configuration

Note: Two or more devices configured with the same IP address can cause unpredictable operation of your network.

Install and maintain a process that assigns a unique IP address to every device in the network.

3.1 Making basic settings

In case of initial installation, enter the IP parameters. The device provides multiple options for configuring IP addresses:

- ▶ Entry via V.24 connection
- ▶ Entry using the HiDiscovery protocol via the HiDiscovery or Industrial HiVision application (via internal port)
- ▶ AutoConfiguration Adapter
- ▶ Web Interface
- ▶ SSH

Further information on the basic settings of the device can be found in the “Configuration” user manual on the CD ROM.

■ Default settings

- ▶ Ethernet ports: link status is not evaluated (signal contact)
- ▶ IP address: DHCP default setting off
Static IP address: 192.168.1.1/24
- ▶ Optical 100 Mbit/s ports: 100 Mbit/s full duplex
Other ports: autonegotiation
- ▶ Password for management:
user, password: public (read only)
admin, password: private (read/write)
- ▶ V.24 data rate: 9,600 Baud

3.2 Firewall and VPN functions

3.2.1 Firewall functions

The EAGLE One device supports the following firewall modes:

- ▶ Stateful Inspection Firewall
- ▶ Transparent Firewall

- ▶ Configurable firewall rules:
 - ▶ Incoming/outgoing data traffic
 - ▶ Modem access
 - ▶ External Management access
- ▶ IP Masquerading, 1-to-1 NAT, port forwarding
- ▶ IP Spoofing Protection

3.2.2 VPN functions

The EAGLE One supports the following Virtual Private Network (VPN) Functions:

- ▶ Hirschmann VPN: router mode
- ▶ VPN protocols: IPSec
- ▶ Encryption algorithms:
 - ▶ DES-56
 - ▶ 3DES-168
 - ▶ AES-128, AES-192, AES-256
- ▶ Authentication:
 - ▶ Pre-shared key (PSK)
 - ▶ X.509v3 certificates
- ▶ Hashing algorithms: MD5, SHA-1
- ▶ NAT-T support

3.3 Operating modes

This device supports you in protecting the internal network against the influences of external networks.

3.3.1 Delivery state

On delivery, the device works in the Transparent mode. In this mode, no network settings (e.g., for subnetworks) are required for operation.

The firewall has been preconfigured so that the IP data traffic from the internal network is possible; however, traffic from the external network to the internal one is not possible. Thus, even the delivery state helps to prevent unauthorized access from the external network.

3.3.2 Transparent mode

The Transparent mode is a transparent bridge mode. In this mode, the device operates as a 2-port bridge, whereby the device transmits IP and ARP packets corresponding to the firewall rules exclusively.

In the delivery state, you have the option of accessing the device via address 192.168.1.1/24 without configuring the IP address.

3.3.3 Router mode

In the Router mode, the device works as a 2-port router. You find a detailed description of the IP configuration in the “Configuration” user manual of the EAGLE One device.

Note: In the Router and Transparent modes, the device provides an additional network access option to the internal network. This access is through the V.24 interface of the EAGLE One device via PPP. In this case, communication is possible with the EAGLE One device and with the devices in the internal network (according to the firewall rules for the modem connection).

3.3.4 PPPoE mode

In PPPoE mode, the EAGLE One device works like in the router mode, with the difference that the device uses the PPPoE protocol at the external port. This provides you the option of connecting to the Internet through a DSL modem.

3.4 Starting Configuration

To access the EAGLE One, proceed as follows (device in the delivery state):

- Install the required Java plugin on your computer.
You find information about the plug-in and its installation in the “User Manual Configuration”.
- Connect your computer to the internal port, and start an https-capable Web browser on your computer in order to configure the EAGLE One.
- Enter the following address in the Web browser:
`https://192.168.1.1/`

Result: The browser sets up an HTTPS connection to the EAGLE One. The browser displays a security message.

- Confirm the security message with “Yes”.
- To login to the device, enter the following:
 - Login: admin
 - Password: private
(case-sensitive)

Result: The browser displays the administrator website of the EAGLE One.

- Specify the settings of the device in accordance with the “User Manual Configuration”.

Alternatively, you have the option of performing the IP configuration for the Transparent mode using the HiDiscovery protocol. You will find the HiDiscovery software in the CD/DVD included in the delivery.

Note: If the browser fails to set up the configuration connection to the EAGLE One, you find detailed information in the “User Manual Configuration – Industrial Ethernet Firewall EAGLE One”.

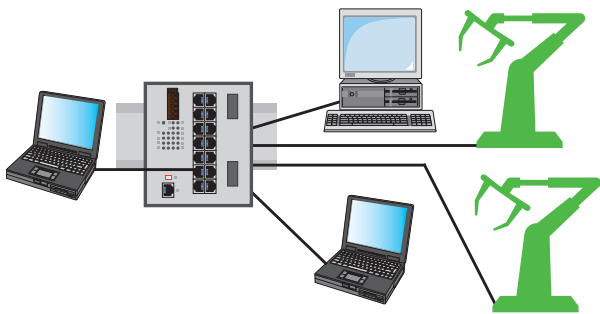

Figure 2: Configuration before the installation of the EAGLE One

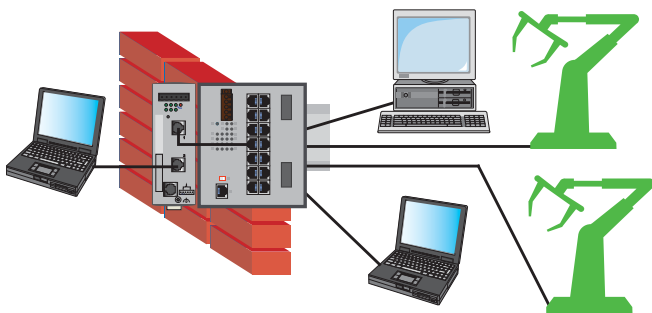

Figure 3: Configuration after the installation of the EAGLE One

4 Monitoring the ambient air temperature

Operate the device below the specified maximum ambient air temperature exclusively.

See [“General technical data” on page 42](#).

The ambient air temperature is the temperature of the air at a distance of 2 in (5 cm) from the device. It depends on the installation conditions of the device, e.g. the distance from other devices or other objects, and the output of neighboring devices.

The temperature displayed in the CLI and the GUI is the internal temperature of the device. It is higher than the ambient air temperature. The maximum internal temperature of the device named in the technical data is a guideline that indicates to you that the maximum ambient air temperature has possibly been exceeded.

5 Maintenance and service

- ▶ When designing this device, Hirschmann largely avoided using high-wear parts. The parts subject to wear and tear are dimensioned to last longer than the lifetime of the product when it is operated normally. Operate this device according to the specifications.
- ▶ Relays are subject to natural wear. This wear depends on the frequency of the switching operations. Check the resistance of the closed relay contacts and the switching function depending on the frequency of the switching operations.
- ▶ Hirschmann are continually working on improving and developing their software. Check regularly whether there is an updated version of the software that provides you with additional benefits. You find information and software downloads on the Hirschmann product pages on the Internet (www.hirschmann.com).
- ▶ Depending on the degree of pollution in the operating environment, check at regular intervals that the ventilation slots in the device are not obstructed.

Note: You will find information about the complaints and returns procedures on the Internet under

<http://www.beldensolutions.com/en/Service/Repairs/index.phtml> .

6 Disassembly

WARNING

ELECTRIC SHOCK

Disconnect the grounding only after disconnecting all other cables.

Failure to follow these instructions can result in death, serious injury, or equipment damage.

- Disconnect the data cables.
- Disable the working voltage.
- Disconnect the terminal blocks.
- Disconnect the grounding.

To remove the device from the DIN rail, you proceed as follows:

- Insert a screwdriver horizontally below the housing into the locking gate.
- Pull the locking gate down without tilting the screwdriver.
- Lift the bottom of the device away from the DIN rail.

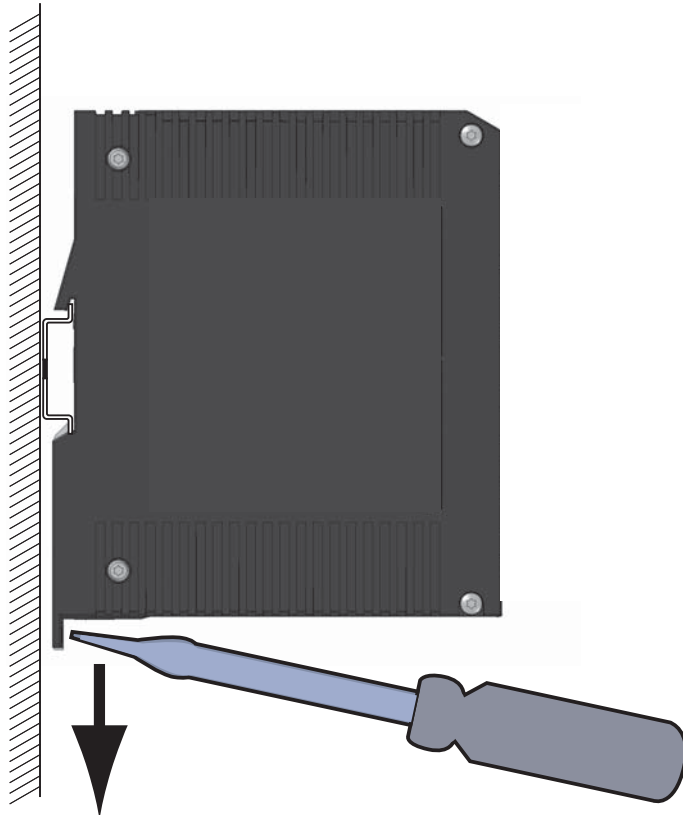

7 Technical data

■ General technical data

Dimensions W × H × D	See "Dimension drawings" on page 44.	
Weight	660 g	
Power supply	<ul style="list-style-type: none"> ▶ 2 voltage inputs for redundant power supply ▶ Safety extra-low voltage (SELV), redundant inputs disconnected 	
Nominal voltage AC	24 V, Class 2	
Voltage range AC incl. maximum tolerances	18 V ... 30 V, Class 2	
Rated voltage range DC	12 V ... 48 V, Class 2	
Voltage range DC incl. maximum tolerances	9.6 V ... 60 V, Class 2	
Connection type	6 pin, screwable terminal block for redundant supply voltage and signal contact	
Power failure bypass	> 10 ms at 20.4 V DC or AC > 2 ms at 10.2 V DC	
Overload current protection at input	Non-replaceable fuse	
Back-up fuse for each voltage input when supply is via 2 inputs	Nominal value at 48 V	1 A
	Nominal value at 24 V	1 A ... 2 A
	Nominal value at 12 V	1 A ... 2.5 A
	Characteristic:	slow blow
Back-up fuse when using 1 voltage input ^a	Nominal value at 48 V	1 A ... 2 A
	Nominal value at 24 V	1 A ... 4 A
	Nominal value at 12 V	1 A ... 5 A
	Characteristic:	slow blow
Peak inrush current	< 14 A	
Climatic conditions during operation	Ambient air temperature ^b	Devices with operating temperature characteristic value S (standard): +32 °F ... +140 °F (0 °C ... +60 °C) Devices with operating temperature characteristic value E and T (extended): -40 °F ... +158 °F (-40 °C ... +70 °C)
	Maximum inner temperature of device (guideline)	Devices with operating temperature characteristic value S (standard): 176 °F (80 °C) Devices with operating temperature characteristic value E and T (extended): 194 °F (90 °C)
	Humidity	10 % ... 95 % (non-condensing)
Air pressure	minimum 795 hPa (+9842 ft; +2000 m) maximum 1060 hPa (-1312 ft; -400 m)	

Climatic conditions during storage	Ambient air temperature ^c	-40 °F ... +185 °F (-40 °C ... +85 °C)
	Humidity	10 % ... 95 % (non-condensing)
	Air pressure	minimum 700 hPa (+9842 ft; +3000 m) maximum 1060 hPa (-1312 ft; -400 m)
Signal contact FAULT	Switching current	max. 1 A, SELV
	Switching voltage	max. 60 V DC, SELV Relevant for North America: max. 30 V DC, Class 2, resistive load
Pollution degree		2
Protection classes	Laser protection	Class 1 in compliance with IEC 60825-1
	Degree of protection	IP20

- a. As an alternative to the back-up fuse is possible:
Voltage supply according to Class 2 or EN 60950-1 Limited Power Source
- b. Temperature of the ambient air at a distance of 2 inches (5 cm) from the device
- c. Temperature of the ambient air at a distance of 2 inches (5 cm) from the device

■ Digital input

Maximum permitted input voltage range	-32 V DC ... +32 V DC
Nominal input voltage	+24 V DC
Input voltage, low level, status "0"	-0.3 V DC ... +5.0 V DC
Input voltage, high level, status "1"	+11 V DC ... +30 V DC
Maximum input current at 24 V input voltage	15 mA
Input characteristic according to IEC 61131-2 (current-consuming)	Type 3

Note: For the pin assignment see ["Wiring the digital input \(optional\)"](#) on page 33.

■ Dimension drawings

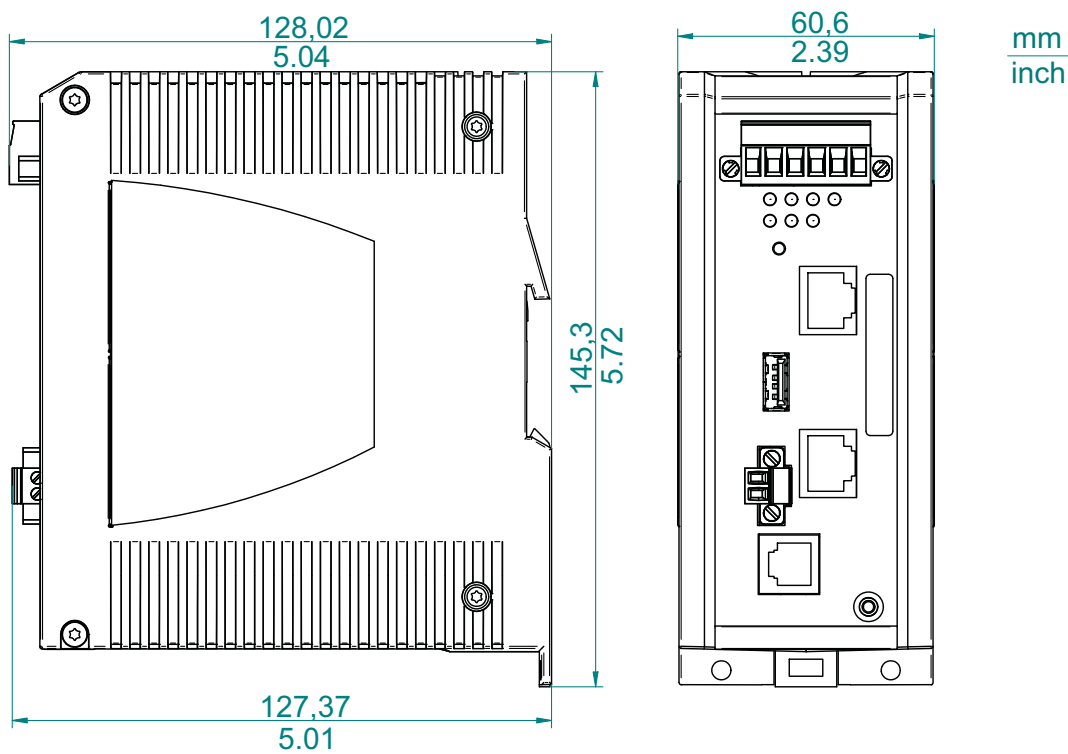

Figure 4: Dimensions

■ EMC and immunity

Note: You will find detailed information on the certificates and declarations applying to your device in a separate overview.

[See table 3 on page 21.](#)

Stability		Standard applications	Navy applications	Railway applications	Substation applications
IEC 60068-2-6, test Fc	Vibration	5 Hz ... 8.4 Hz with 0.14 in. (3.5 mm) amplitude	2 Hz ... 13.2 Hz with 0.04 in. (1 mm) amplitude	—	2 Hz ... 9 Hz with 0.12 in. (3 mm) amplitude
		—	—	—	—
		8.4 Hz ... 150 Hz with 0.04 oz (1 g)	13.2 Hz ... 100 Hz with 0.03 oz (0.7 g)	—	9 Hz ... 200 Hz with 0.04 oz (1 g)
		—	—	—	—
		—	—	—	200 Hz ... 500 Hz with 0.05 oz (1.5 g)
IEC 60068-2-27, test Ea	Shock	0.53 oz (15 g) at 11 ms		—	0.53 oz (10 g) at 11 ms
EMC interference emission		Standard applications	Navy applications	Railway applications (trackside)	Substation applications
Radiated emission					
EN 55022		Class A	Class A	Class A	Class A
GL Guidelines		—	EMC 1	—	—
FCC 47 CFR Part 15		Class A	Class A	Class A	Class A
EN 61000-6-4		Fulfilled	Fulfilled	Fulfilled	Fulfilled
Conducted emission					
EN 55022	AC and DC supply connections	Class A	Class A	Class A	Class A

EMC interference emission		Standard applications	Navy applications	Railway applications (trackside)	Substation applications
GL Guidelines	AC and DC supply connections	—	EMC 1	—	—
FCC 47 CFR Part 15	AC and DC supply connections	Class A	Class A	Class A	Class A
EN 61000-6-4	AC and DC supply connections	Fulfilled	Fulfilled	Fulfilled	Fulfilled
EN 55022	Telecommunication connections	Class A	Class A	Class A	Class A
EN 61000-6-4	Telecommunication connections	Fulfilled	Fulfilled	Fulfilled	Fulfilled

EMC interference immunity		Standard applications	Navy applications	Railway applications (trackside)	Substation applications
Electrostatic discharge					
EN 61000-4-2 IEEE C37.90.3	Contact discharge	± 4 kV	± 6 kV	± 6 kV	± 8 kV
EN 61000-4-2 IEEE C37.90.3	Air discharge	± 8 kV	± 8 kV	± 8 kV	± 15 kV
Electromagnetic field					
EN 61000-4-3 IEEE 1613	80 MHz ... 3000 MHz	10 V/m	10 V/m	20 V/m	10 V/m
	80 MHz ... 1000 MHz	—	—	—	35 V/m
Fast transients (burst)					
EN 61000-4-4 IEEE C37.90.1	AC/DC supply connection	± 2 kV	± 2 kV	± 2 kV	± 4 kV
EN 61000-4-4 IEEE C37.90.1	Data line	± 4 kV	± 4 kV	± 4 kV	± 4 kV
Voltage surges - DC supply connection					
EN 61000-4-5 IEEE 1613	line/ground	± 2 kV	± 2 kV	± 2 kV	± 2 kV
	line/ground	—	—	—	± 5 kV
EN 61000-4-5	line/line	± 1 kV	± 1 kV	± 1 kV	± 1 kV
Voltage surges - data line					
EN 61000-4-5	line/ground	± 1 kV	± 1 kV	± 2 kV	± 4 kV

EMC interference immunity		Standard applications	Navy applications	Railway applications (trackside)	Substation applications
Conducted disturbances					
EN 61000-4-6	150 kHz ... 80 MHz	10 V	10 V	10 V	10 V
Damped oscillation - AC/DC supply connection					
EN 61000-4-12 IEEE C37.90.1	line/ground	—	—	—	2.5 kV
EN 61000-4-12 IEEE C37.90.1	line/line	—	—	—	1 kV
Damped oscillation - data line					
EN 61000-4-12 IEEE C37.90.1	line/ground	—	—	—	2.5 kV
EN 61000-4-12	line/line	—	—	—	1 kV
Pulse magnetic fields					
EN 61000-4-9		—	—	300 A/m	300 A/m

■ Network range

Ports	Wave length	Fiber	System attenuation	Example for F/O line length ^a	Fiber attenuation	BLP/ dispersion
MM	1300 nm	50/125 µm	0-8 dB	0-5 km	1.0 dB/km	800 MHz*km
MM	1300 nm	62.5/125 µm	0-11 dB	0-4 km	1.0 dB/km	500 MHz*km

Table 11: F/O port 100BASE-FX

a. including 3 dB system reserve when compliance with the fiber data is observed

MM = Multimode

10/100/1000 Mbit/s twisted pair port

Length of a twisted pair segment max. 100 m (for cat5e cable)

■ Power consumption/power output

Device variant	Maximum power consumption	Power output
EAGLEONE-0200T1T1.....	5 W	17 Btu (IT)/h
EAGLEONE-0200T1M2.....	6 W	20 Btu (IT)/h
EAGLEONE-0200M2T1.....		
EAGLEONE-0200M2M2.....	7 W	24 Btu (IT)/h

■ Scope of delivery

Number	Article
1 ×	Device
1 ×	6 pin, screwable terminal block for redundant supply voltage and signal contact
1 ×	2 pin, screwable terminal block for digital input
1 ×	Installation user manual
1 ×	CD/DVD with manual

■ Accessories

Note: Please note that the technical data of products recommended as accessories may differ in certain points from the technical data of the device. In these cases, the less favorable value of the technical data applies. If for example a device has a degree of protection of 65/67 and a product has a degree of protection of 20, the combination of both has a degree of protection of 20.

Other accessories	Order number
AutoConfiguration Adapter ACA 21-USB (EEC)	943 271-003
Terminal cable	943 301-001
6-pin, screwable terminal block (50 pcs.)	943 845-013

Other accessories	Order number
Wall mounting plate for DIN rail mounting, width 2.36 in. (60 mm)	943 971-003
Rail Power Supply RPS 30	943 662-003
Rail Power Supply RPS 80 EEC	943 662-080
Rail Power Supply RPS 120 EEC (CC)	943 662-121
Industrial HiVision Network Management Software	943 156-xxx
OPC server software HiOPC	943 055-001

■ Underlying technical standards

Name	
CSA C22.2 No. 213	Canadian National Standard(s) for Nonincendive Electrical Equipment for Use in Class I, Division 2 Hazardous Locations
EN 50121-4	Railway applications – EMC – Emission and immunity of the signalling and telecommunications apparatus (Rail Trackside)
EN 55022	Information technology equipment – Radio disturbance characteristics – Limits and methods of measurement
EN 60079-0	Explosive atmospheres – Part 0: Equipment – General requirements
EN 60079-11	Explosive atmospheres – Part 11: Equipment protection by intrinsic safety “i”
EN 60079-15	Explosive atmospheres – Part 15: Equipment protection by type of protection “n”
EN 60950-1	Information technology equipment – Safety – Part 1: General requirements
EN 61000-6-2	Electromagnetic compatibility (EMC) – Part 6-2: Generic standards – Immunity for industrial environments
EN 61000-6-4	Electromagnetic compatibility (EMC) – Part 6-4: Generic standards – Emission standard for industrial environments
EN 61131-2	Programmable controllers – Part 2: Equipment requirements and tests
FCC 47 CFR Part 15	Code of Federal Regulations
Germanischer Lloyd	Rules for Classification and Construction VI-7-2 – GL
IEC 60825-1	Safety of Laser Products
IEC/EN 61850-3	Communication networks and systems in substations – Part 3: General requirements
IEEE 1613	IEEE Standard Environmental and Testing Requirements for Communication Networking Devices in Electric Power Substations
ISA 12.12.01	United States Standard for Safety for Nonincendive Electrical Equipment for Use in Class I and II, Division 2 and Class III, Divisions 1 and 2 Hazardous (Classified) Locations
UL 508	Safety for Industrial Control Equipment

Table 12: List of technical and industry standards

The device generally fulfills the technical and industry standards named in their current versions.

The device has an approval based on a specific standard or de facto standard only if the approval indicator appears on the housing.

If your device has a shipping approval according to Germanischer Lloyd, you find the approval mark printed on the device label. You will find out whether your device has other shipping approvals on the Hirschmann website under www.hirschmann.com in the product information.

A Further Support

■ Technical Questions

For technical questions, please contact any Hirschmann dealer in your area or Hirschmann directly.

You will find the addresses of our partners on the Internet at <http://www.hirschmann.com>

Contact our support at <https://hirschmann-support.belden.eu.com>

You can contact us

in the EMEA region at

- ▶ Tel.: +49 (0)1805 14-1538
- ▶ E-mail: hac.support@belden.com

in the America region at

- ▶ Tel.: +1 (717) 217-2270
- ▶ E-mail: inet-support.us@belden.com

in the Asia-Pacific region at

- ▶ Tel.: +65 6854 9860
- ▶ E-mail: inet-ap@belden.com

■ Hirschmann Competence Center

The Hirschmann Competence Center is ahead of its competitors:

- ▶ Consulting incorporates comprehensive technical advice, from system evaluation through network planning to project planning.
- ▶ Training offers you an introduction to the basics, product briefing and user training with certification.

The current technology and product training courses can be found at <http://www.hicomcenter.com>

- ▶ Support ranges from the first installation through the standby service to maintenance concepts.

With the Hirschmann Competence Center, you have decided against making any compromises. Our client-customized package leaves you free to choose the service components you want to use.

Internet:

<http://www.hicomcenter.com>



HIRSCHMANN

A **BELDEN** BRAND